

**Not recommended for new designs!
(Please use successor EtherCAN/2)**



EtherCAN

CAN-ETHERNET-Gateway

- ARM-processor NET+50
- 10/100BaseT ETHERNET
- CAN interface
- CANopen manager
- hat-rail case

ARM Controlled Module

The EtherCAN is an ETHERNET-CAN gateway with an NET +50 ARM processor that controls the data transfer between CAN and ETHERNET. The module is designed for hat-rail mounting in a control enclosure. The connectors and status LEDs are mounted in the front panel.

Fast ETHERNET Interface

The ETHERNET interface is designed for 10 Mbit/s and 100 Mbit/s nets. It is accessible via an RJ45 connector in the front panel. See the order information below for supported ETHERNET communication protocols.

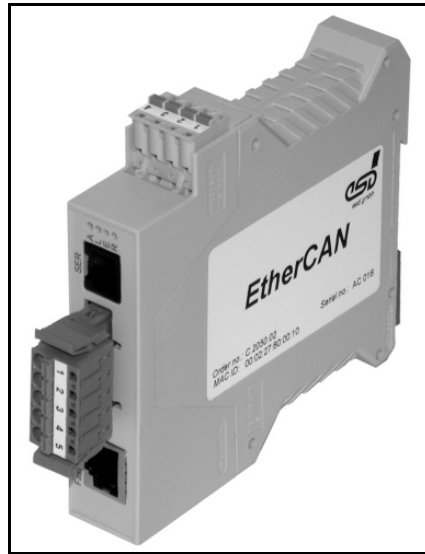

CAN Interface

The CAN interface is based on a SJA1000 CAN controller.

The interface is designed according to ISO 11898 with electrical isolation and a Combicon-style connector. It allows data transfer rates of 1 Mbit/s.

Software Support

The complete firmware for the data transfer between the nets is onboard stored in Flash-EPROM. In addition Software-drivers are available for Windows NT/2000/XP and Linux.

The monitor program CANscope is in the scope of delivery. Drivers for other operating systems are also available.

CAN-Protocol

Software packages for CANopen are available for Windows 98/NT/2000/XP or UNIX-systems.

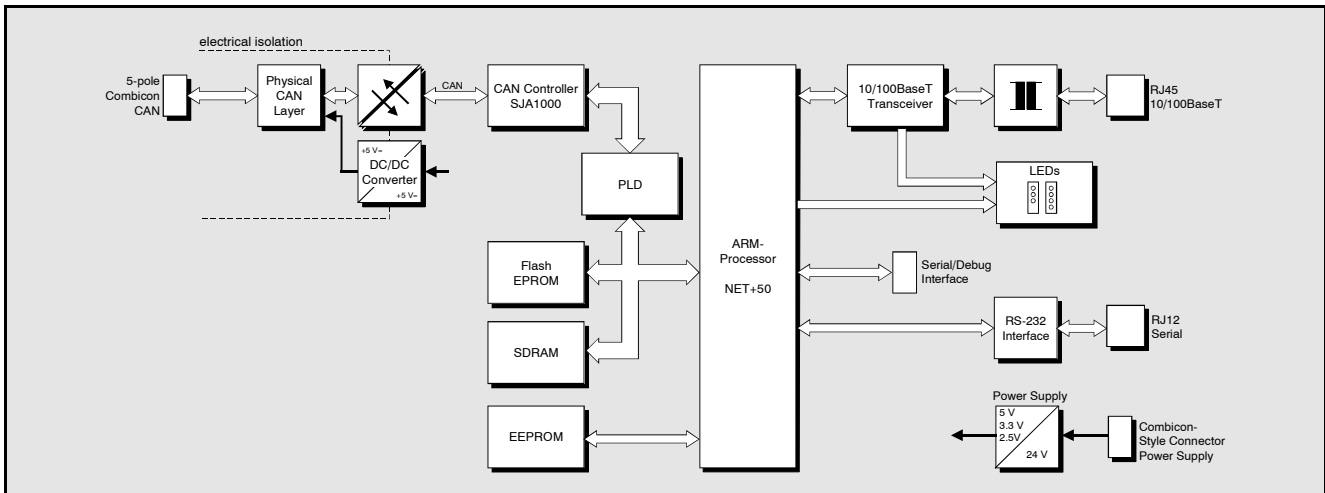

Technical Specifications:

Microcontroller:

Microcontroller: ARM NET +50

Memory equipped: from 2 M x 32 bit SDRAM (8 MB), up to 8 M x 32 bit SDRAM (64 MB), up to 8 M x 8 bit Flash EPROM (1,2,4,8 MB)

Interfaces:

ETHERNET: 10/100BaseT, IEEE802.3, RJ45-connector

CAN: controller SJA1000, CAN 2.0A/B, electrically isolated, 1 Mbit/s, ISO11898, Combicon-style connector

Serial: one internal interface for service and programming only, TTL-level signals, one RS-232 interface at RJ12

General:

Ambient temperature: 0...50 °C

Humidity: max. 90 %, non-condensing

Power supply: 24 V

Connectors: CAN: 5-pole Combicon-style, 10/100BaseT: RJ45, RS-232: RJ12
Power: 4-pole Combicon-style

Order information:

Designation		order no.
EtherCAN	CAN-ETHERNET-Gateway, 2 MB Flash, 16 MB SDRAM	C.2050.02
CAN-DRV-LCD	Object licence for Windows and Linux incl. CD-ROM	C.1101.02
EtherCAN-NT	CAN-ETHERNET gateway, bundle with WinXP/2K and Linux driver, CAN-API	C.2050.03
EtherCAN-ELLSI	UDP/TCPIP Socket-Interface	C.2050.06
EtherCAN-ME	Hardware manual	C.2050.21
CAN-API-ME	Software manual CAN-API	C.2001.21