

CAN-Mini-ADI4/DO4

4 Digital/Analog Inputs, 4 Digital Outputs

- 4 input ports, usable as analog or digital inputs
- 4 digital outputs 12 V / 24 V
- easy wiring

Multi Functional Input Ports

The four input ports of the module can be set by software and/or solder bridges to four different operating modes. The setting can be made for each channel individually. It is possible to select between the modes 'digital input' and 'analog input' by software in the default configuration of the hardware. If the solder bridges are modified the modes 'switch input' and 'resistance measuring' will be possible.

Digital Outputs

The four digital outputs of the module can operate with a power supply voltage of 12 V or 24 V.



LED Display and Coding Switch

The status LEDs display the status of the input and output ports, the CAN status and the general module status.

The coding switch is used to set the bit rate and the Node-ID.

Intelligent Microcontroller

The CAN-Mini-ADI4/DO4 module is equipped with a C505C-microcontroller with an integrated CAN interface (CAN 2.0B).

The firmware is stored in a Flash-EEPROM. An external EEPROM is used to store the data of the module configuration.

CAN Bus

The physical CAN layer is ISO 11898-compliant and allows data-transfer rates of up to 1 Mbit/s. It is connected via screw/plug connectors.

CAN Protocols

The module is operating with CANopen according to CiA-DS401.

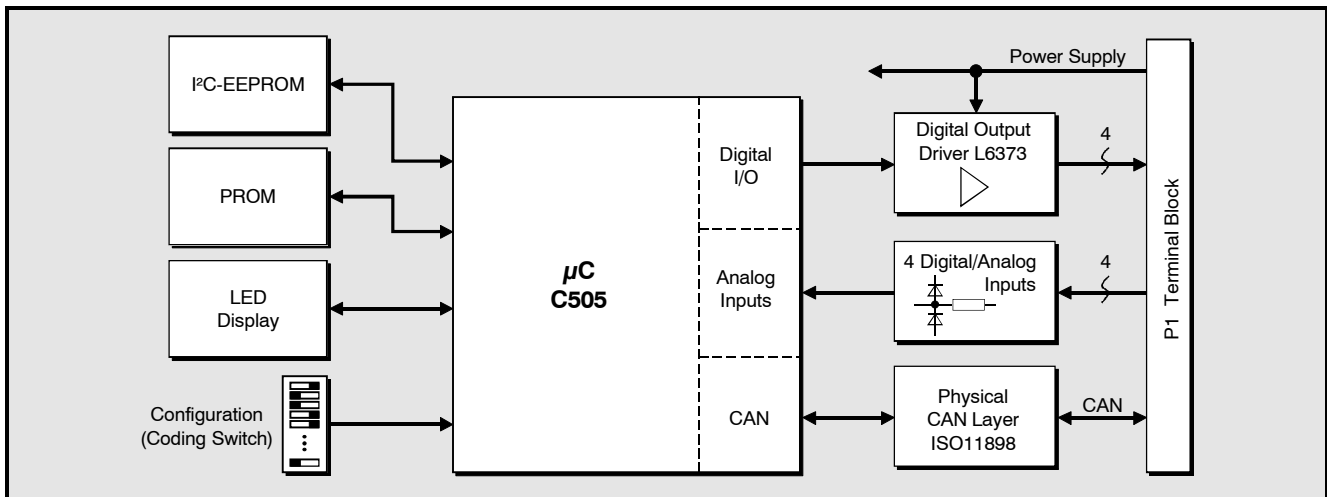

Technical Specifications:

Process coupling:

Inputs: 4 input ports, operating modes:
 - digital input (0...30 V)
 - analog input (10 bit, 0...5 V),
 - switch input (low side or high side switch)
 - resistance measuring ($R_{REF} = 10 \text{ k}\Omega$) of NTCs, PTCs and PT1000

Outputs: supply voltage 12 V(DC) or 24 V(DC), load 0,5 A (24 V, 25 °C), protection circuits: internal current limitation, shutdown at overheating and under voltage, error messages

CAN:

CAN controller: C505C
CAN interface: differential, 1 Mbit/s, ISO11898, no electrical isolation of physical layer
Protocol: CANopen

General:

LED display: status of I/Os, CAN and general module status
Ambient temperature: 0...50 °C
Operating voltage U_s : 12 V(DC) or 24 V(DC)
Case dimensions: 25 mm x 79 mm x 91 mm
 DIN-EN carrier rail mounting

Order information:

Designation		order no.
CAN-Mini-ADI4/DO4	4 digital or analog inputs, 4 digital outputs, CANopen	C.2080.01
CAN-Mini-ADI4/DO4-MD	English users's manual	C.2080.21