

# Windows CAN Starter Kit

## CAN-Starter-Kit

You always wanted to know

- what is CAN ?
- how does CAN work ?
- how can CAN be applied ?

## Here is your solution

- PC CAN interface (CAN-USB or CAN-PCI/200 or CAN-PCI/331 or CPCI-CAN/331)
- digital I/O-Module CAN-CBM-DIO8
- simulation block CBM-CSK1
- wiring incl. terminations etc.
- power supply
- drivers, operator software for Windows
- operating manual

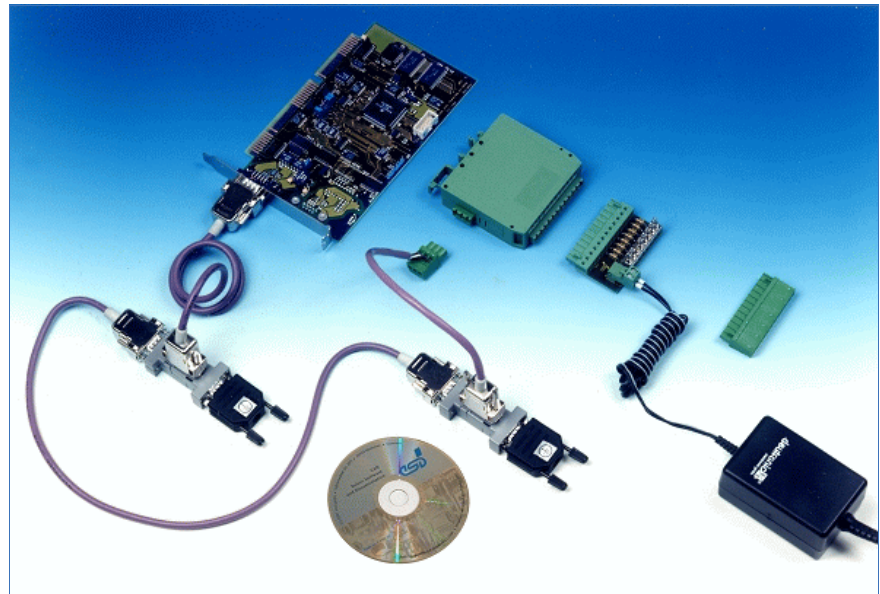

CAN-Starter-Kit with CAN-PC board

## A complete package

The complete package is designed for gaining knowledge and experience with CAN in an application. Our kit contains a PC-CAN interface, a digital I/O module (8 channels), the I/O wiring, a simulation block, a power supply, the CAN network including T-connector and terminations, documentation as well as drivers and operator software for Windows.

The parts of the CAN starter kit can be reused and comply with the CiA standards and industrial requirements. Of course, all CAN nodes are electrically isolated.

## Really simple

After all components are interconnected according to the documentation, and the driver as well as the demo program are installed on the PC, you can already start. With one Mbit per second you can transfer data from and to the PC. Really simple!

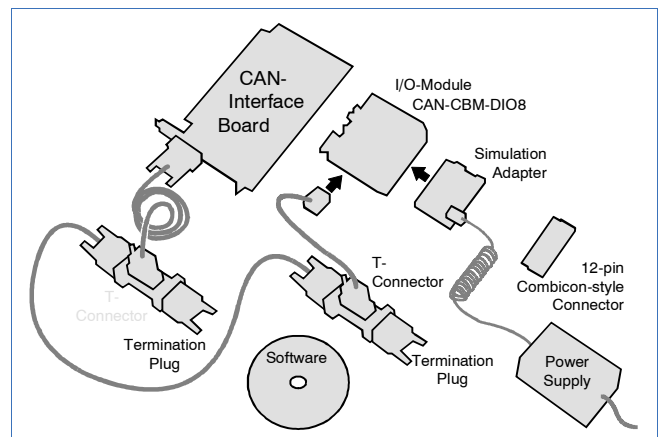

Components of the Windows-CAN-Starter-Kit

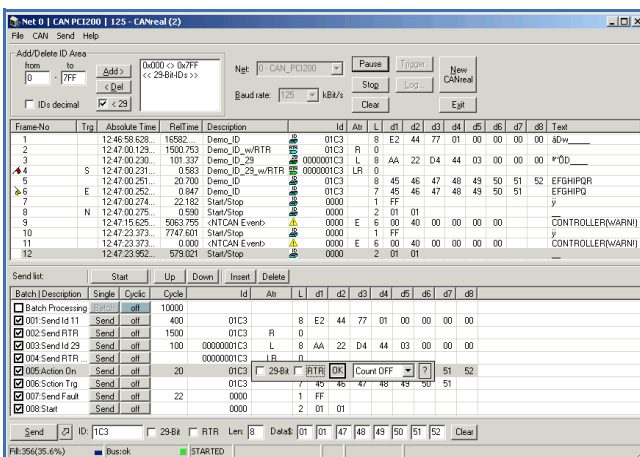

Monitor Program CANreal

## Software Included

The Windows software package includes the self explaining monitor program CANreal. It can be used to send CAN messages and to monitor each transmitted CAN message on the bus.

Caused by the standardized software interface of the esd PC boards your application program will also run with other esd PC boards.

Another advantage is that you can connect further components to your CAN network without great efforts.

Each board of our program can be combined with the starter kit on demand.

# Windows CAN Starter Kit

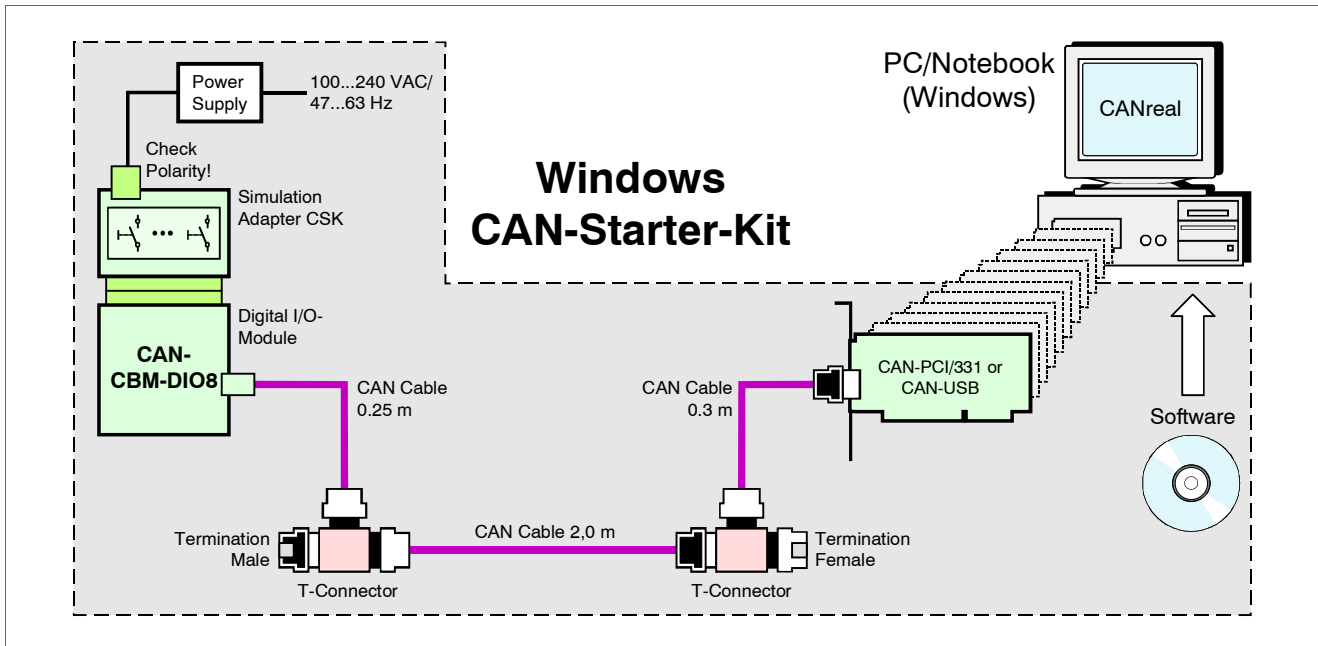

## Technical Specifications:

### CAN-PC Boards:

	CAN-PCI/200	CAN-PCI/331	CAN-USB
Host interface	PCI	PCI	USB 1.1 (2.0 also available)
CPU/microcontroller	passive	CPU 68331	16-bit microcontroller
CAN controller	SJA1000, CAN ISO11898-1		
CAN interface	acc. to ISO11898-2, electrically isolated, bit rate 1 Mbit/s (typ. at 37 m bus length)		

### CAN-CBM-DIO8:

CAN interface: acc. to ISO 11898, electrically isolated, 1 Mbit/s (max. 10 m bus length), 500 kbit/s (max. 80 m)

Microcontroller: C515C

Digital I/Os: 8 channels, each channel can be setup as an input or output separately, nominal voltage 24 V

### CAN-CSK board::

I/O simulation: load resistors for each output, switches for each input

power supply: power supply connector for CBM

### CAN wiring:

Cables: shielded twisted pair bus cables, connector plugs cases made of chrome plated plastic

T-connectors: two female and one male connector each

Termination plugs: 120 ohm termination resistor, 4.8 mm fast-on male connector to connect CAN\_GND to earth potential

### Software of CAN-Starter-Kit:

CAN-CBM-DIO8: module supports the CANopen protocol

CAN-PC boards: driver for Windows, CANreal

### General:

Ambient temperature: 0 ... +50 °C

Relative humidity: max. 90 %, non-condensing

### Scope of delivery:

- 1 CAN-PC board with CAN interface (CAN-PCI/200, CAN-PCI/331, CPCI-CAN/331 or CAN-USB)
- 1 CAN-CBM-DIO8
- 1 CSK board for I/O simulation
- 1 power supply (24 V/DC)
- 1 CAN cable 0.25 m (for CAN-CBM-DIO8)
- 1 CAN cable 0.3 m (standard)
- 1 CAN cable 1.0 m (standard)
- 2 T-connectors (female-female-male)
- 1 termination plug female
- 1 termination plug male
- 1 12-pin combicon-style screw/plug connector (replaces CSK board in field application)
- set software drivers and CANreal at CD
- 1 set of documentation

### Order information:

Designation	order no.
Windows-CAN-Starter-Kit with CAN-PCI/200-1 (scope of delivery as listed)	C.2030.05
Windows-CAN-Starter-Kit with CAN-PCI/331-1 (1x CAN) (scope of delivery as listed)	C.2030.03
Windows-CAN-Starter-Kit with CPCI-CAN/331-1 (1x CAN) (scope of delivery as listed)	C.2030.07
Windows-CAN-Starter-Kit with CAN-USB-Mini (scope of delivery as listed)	C.2030.09