

# VME-PMC-CPU/2-CC

PowerPC Processor Board with 2 PMC Slots Conduction Cooled

## VMEbus Interface

- master or slave functionality
- 4-level arbiter
- address/data up to A64/D64
- VME64-extension connector
- 2eVME and 2eSST fast protocol

## PowerPC CPU

- Freescale MPC 8349
- 533 MHz
- 512 Mbyte DDR2 RAM ECC (optional up to 1 Gbyte)
- 128 Mbyte Flash (NOR)
- 2 Gbyte NAND Flash
- XC3S1600E FPGA (shared with NAND Flash interface)
- 1x Gbit Ethernet
- 2x RS-232 serial interface

## PMC Slots

- slots according to IEEE Std 1386-2001 specified
- two single size PMC modules insertable
- VME-PCI bridge Tundra Tsi148
- PMC I/Os applied to VMEbus P2, signals routed acc. to VITA 35 (P4V2-64ac, P4V0-64)
- option '-32P2': different P2-pinning
- PPMC according to VITA 32
- one XMC according to VITA 42.3
- PCI 64 bit at 66 MHz, 3.3 V only

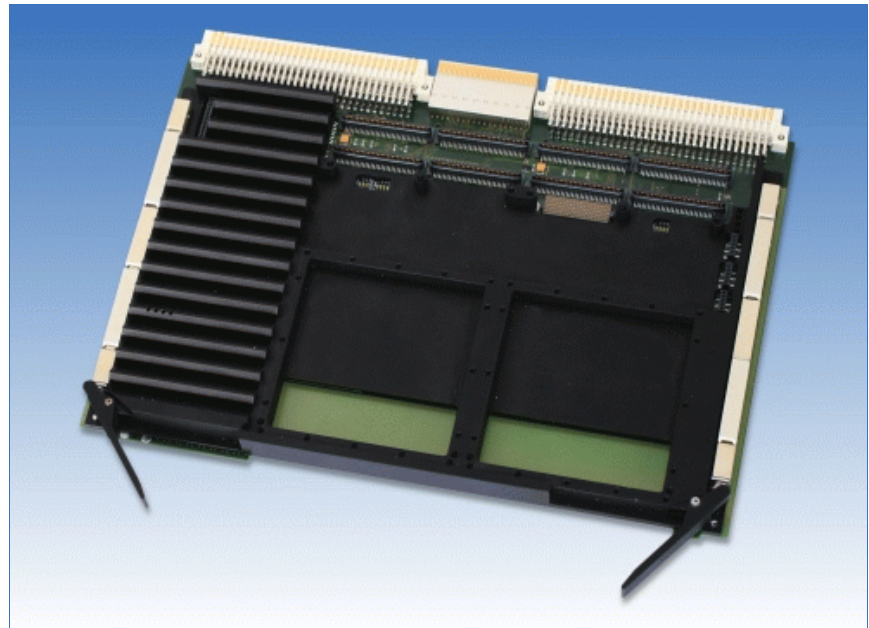

## VME-PCI Link

The VMEbus unit VME-PMC-CPU/2 is a VME64-base board which can carry up to two PMC modules of normal size. For the VMEbus connection the VME-PCI bridge Tsi148 by Tundra is used.

## VMEbus Interface

The Tsi148 is designed in a way that the board can either operate as slave or as master on the VMEbus. If the board operates as master, it supports a 4-level arbiter. The VMEbus interrupt can be applied to any of the seven interrupt-request lines. The board is connected to the VMEbus by two 160-pin VG-connectors (complementary to DIN41612) for VME64 systems.

## PowerPC CPU

A high efficient PowerPC MPC8349 powers the board at 533 MHz with the advantage of a frugal power consumption. The fast floating point unit of type 603 allows complex algorithms at formidable speed. The memory enables ECC with a capacity of 512 Mbyte or optional 1 Gbyte DDR2-typed RAM. The flash memory of 2 Gbyte allows even complex and ambitious operating systems as well as user's application.

The on-board FPGA controls the set-up of the board resources, including the complex Tsi148 VME interface and the PMC slots, but is mighty enough to enable a programming API for the programmers usage.

Furthermore the board comes with 1 Gbit Ethernet port and 2 RS-232 serial ports with access via P0 rear I/O pins.

## PMC Slots

Both PMC slots are designed according to the standard IEEE Std 1386-2001 (except the standard I/O pin routing). It is possible therefore to insert all PMC modules, that use 3.3 V signalling only.

In addition to the connectors for the PMC-address/data and control signals, every slot of the VME-PMC-CPU/2 has an I/O-connector which applies the I/O-signals of the PMC modules to VMEbus connector P2. Two different P2 pin assignments are available: In the standard configuration each P2-pin is only connected to one I/O-pin of the PMC-modules acc. to VITA 35 (P4V2-64ac, P4V0-64).

In the option '-32P' the pin assignment is acc. to IEEE Std 1386-2001, Table 8. This pin assignment offers the connection of the two PMC-modules via P2, because several PMC-I/O-signals are shorted at P2.

## Software

BSPs are available for VxWorks, Linux and QNX.

# VME-PMC-CPU/2-CC

PowerPC Processor Board with 2 PMC Slots Conduction Cooled

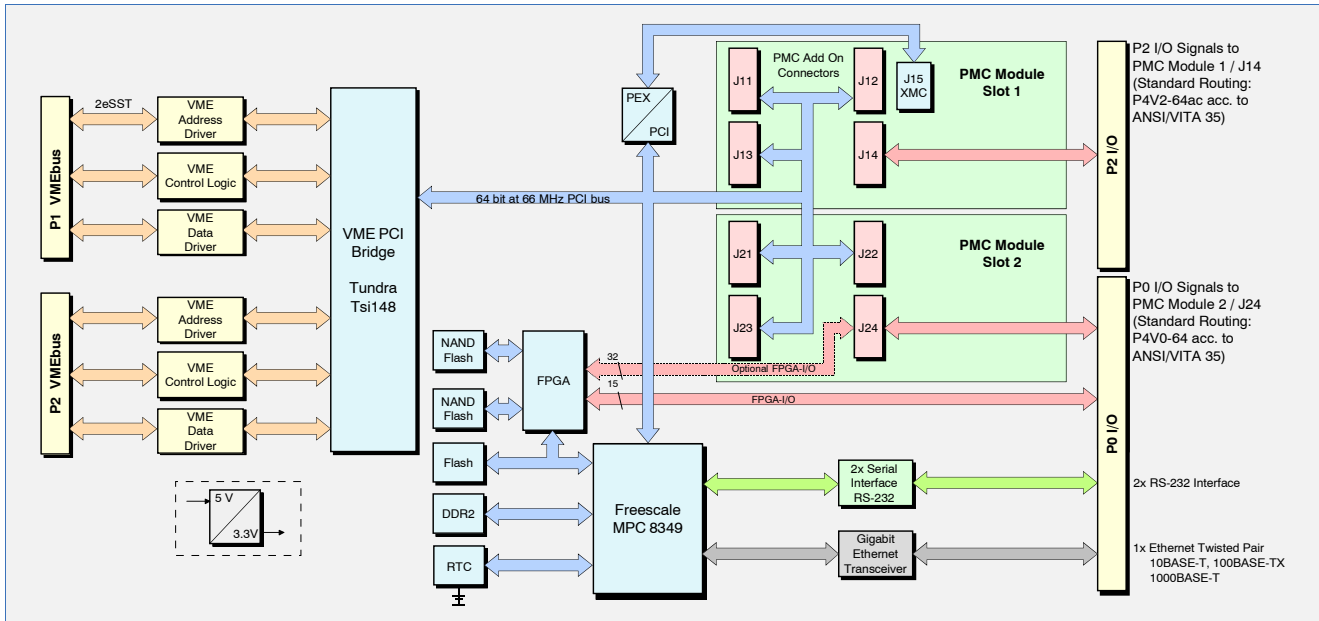

## Technical Specifications:

### VMEbus:

Controller:	TUNDRA Tsi148
VMEbus access:	- legacy protocols to protect existing VME investment - VME64 extensions - 2eVME and 2eSST protocols
Base address:	geographical addressing
Address modifier:	standard supervisory and nonprivileged data access, extended supervisory and non-privileged data access, short supervisory and nonprivileged access
VMEbus standard:	IEEE 1014 Rev. D
VMEbus connector:	160-pole VG connector (complementary to DIN 41612), acc. to VME64 extension standard

### PMC/XMC slots:

Standard:	IEEE Std 1386-2001
Size:	two single size modules
VME PCI Bridge:	Tundra Tsi148, 32/64 bit at 33/66 MHz
PCI Voltage level:	3.3 V (signal level) only
XMC:	slot 1 with 4 lane XMC interface (J15) according to VITA 42.3 standard
Voltage option:	on-board 3.3V generation

### General:

Temperature:	-40...+85 °C
Humidity:	max. 90 %, non-condensing

### General (continued):

Connector types:	P1, P2: VMEbus (160 pins) P0: VMEbus (114 pins) J11, J12, J21, J22: PMC address/data J13, J23: PCI 64 signals J14, J24: PMC I/O signals J15: XMC
Board size:	160 mm x 233 mm
VME dimensions:	6 U height, 4 HP width

### Order information:

Designation		Order no.
VME-PMC-CPU/2-CC	VMEbus base board for two single PMC modules, P2-pin assignment acc. to VITA 35 (P4V2-64ac, P4V0-64), (no interconnection between PMC modules), conduction cooled, extended temperature range: -40...+85 °C	V.1917.03
VME-PMC-CPU/2-CC-32P2	VMEbus base board for two single PMC modules, P2-pin assignment acc. to IEEE Std 1386-2001, Table 8 (interconnection between 16 pins of the PMC-modules), conduction cooled, extended temperature range: -40...+85 °C	tbd.
VME-PMC-CPU/2-Linux	Linux BSP	V.1917.57
VME-PMC-CPU/2-VxWorks	VxWorks BSP	V.1917.58
VME-PMC-CPU/2-QNX	QNX BSP	V.1917.59
VME-PMC-CPU/2-ME	English users' manual	V.1917.21