

VME-ADTH16

16 Analog Thermal Inputs

Not recommended for new designs!

16 Inputs

- 16 real thermal inputs with cold junction compensation
- 12 bits resolution
- Each channel separately adjustable

Optoisolation

- Safety of operation by electrical isolation between VMEbus and process environment

LED Display

- Easy diagnosis by display of 'Power-Fail' and other actual states on the front panel

Wiring via P2

- Proper wiring of analog inputs to the backplane via P2

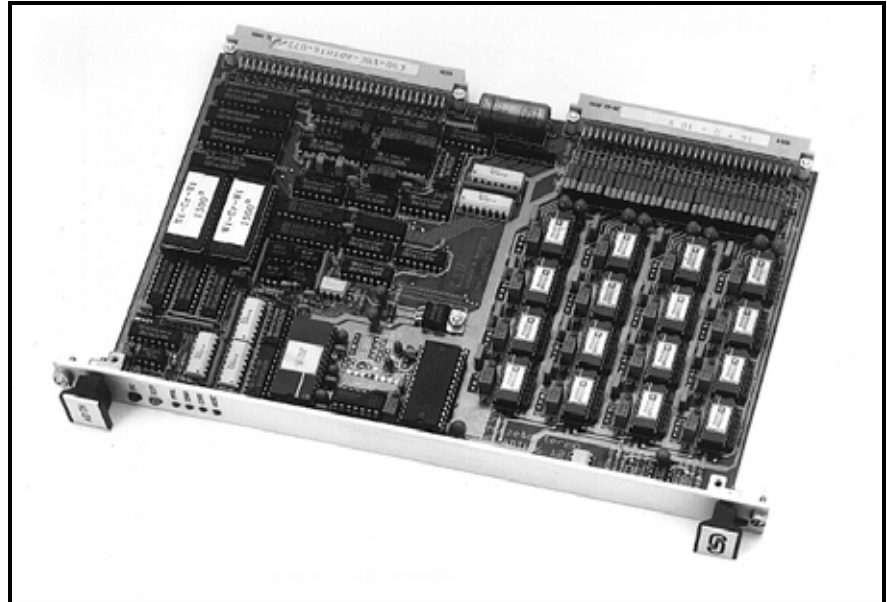

16 Thermocouple Inputs

VME-ADTH16 contains 16 differential input channels, especially intended for the connection of thermocouples. Each input is equipped with an integrated instrumentation amplifier (AD524) with selectable gain. The gain can also have a customized value (to be specified when ordering). A low-pass filter at every input provides for normal noise suppression (3 dB cut-off frequency is 16 Hz with standard component parts, others upon request).

The amplified signals are fed to the 12 bits A/D converter via a 16 x 1 multiplexer.

All control and data lines between VMEbus section and process section are optoisolated.

Linearization EPROM on Board

On the digital side the signals can be linearized by an EPROM for each channel separately. Therefore different types of thermal elements may be connected to the same board.

After setting the channel number and starting the conversion the evaluation program is able to read the linearized value as well as the simply converted value. Furthermore under program control it is possible to apply an arbitrary digital signal to the linearizing EPROM and let it be linearized. Thus the gain and the offset of each thermal channel can be checked during the operation.

Additionally, 8 optoisolated TTL outputs (e.g. for strobes) are on the board.

LED Display

Easy diagnosis of the actual conditions of the VME-ADTH16 is possible by means of LED displays on the front panel for:

Board select, convert, semaphore bit and monitoring of internal (+5 V) and external power supplies (± 15 V) (PFAIL).

Software Support

The operation manual contains detailed programming applications for the setting of a channel and for the starting of a conversion.

Control of the VME-ADTH16 via VMEbus is easily done with simple commands, so that no driver is necessary. Nevertheless drivers for all popular operating systems are available.

VME-ADTH16

16 Analog Thermal Inputs

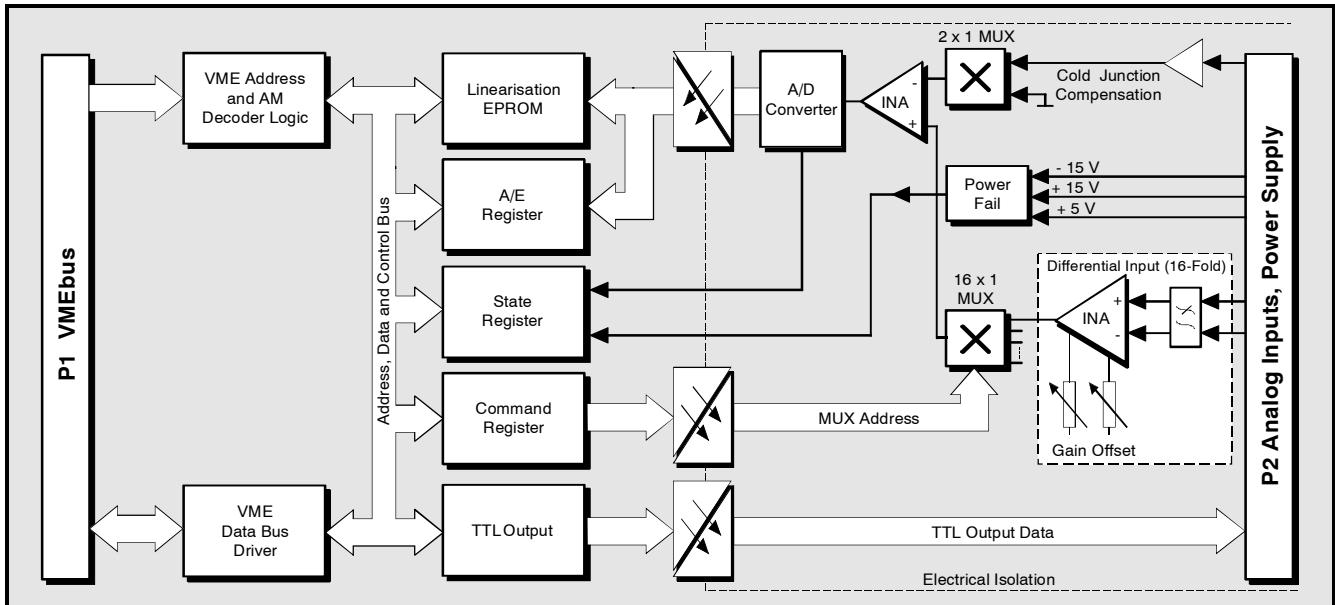

Technical Specifications:

Process section:

Inputs:	16 differential analog inputs with 16 Hz low-pass filters
Resolution:	12 bits
Accuracy:	0.05 % to 0.5%, depending on sensor and range
Gain:	1, 10, 100, 1000 and customer specific
Sample rate:	typ. 8 Hz
Input signals:	thermocouples or 0...+10 V, 0(4)...20 mA, for each channel separately selectable
Approved types of thermocouples:	NiCr-Ni (type K) PtRh-EL18 (type B) Fe-CuNi (type J) PtRh-Pt (type S) (examples, many others are possible) Fe-CuNi according to DIN 43710, Pt100 (with adapter VME-ADTH-PT100)

Thermo linearization:	for each channel separately programmable (EPROM)
Outputs:	8 TTL outputs from an optocoupler TLP 521
LED array:	BUSY (board select), PFAIL (+15 V, -15 V, +5 V), CONV (convert), SEMA (semaphore)
Electrical isolation:	by optocouplers

VMEbus section:

Base address:	selectable by jumpers over the whole address range of 16 Mbyte. The board covers 256 bytes.
Address modifier (AM):	full AM decoding additionally with don't care mode for 'supervisory'/'nonprivileged' mode
VMEbus revision compatibility:	IEEE 1014 rev. C.1
Data transfer options:	SADO24, SD16

General:

Ambient temperature:	0...70 °C
Humidity:	max. 90%, non-condensing
Connector types:	P1: DIN 41612-C96 P2: DIN 41612-C64
Board size:	160 mm x 233 mm
VME dimensions:	6U height, 1 slot width
Weight:	400 g
Power consumption:	1 A at 5 VDC
External power consumption for analog section:	+15 V / 200 mA -15 V / 100 mA

Order information:

Designation		Order no.
VME-ADTH16	16 analog inputs for thermocouples	V.1703.02
VME-ADTH16-X	Boards for standard types of thermocouples are available for a special price. Please check the price list or contact your local distributor.	
VME-ADTH-PT100	Adapters for 16 x Pt100 thermo elements	V.1703.06
VME-AD16-ADAPT1	Adapter module with screw terminal blocks, connection to P2	V.1701.06
VME-AD16-ADAPT2	Adapter module with clamp terminal blocks, connection to P2	V.1701.07
VME-AD16-P2VCC	15 V connection for P2	V.1701.90
VME-DVPS30/15	Dual voltage power supply, 30VA, linear, ±15V	V.1910.15
VME-ADTH16-OS9	C driver for OS-9 as source code	P.1703.50
VME-ADTH16-VxW	C driver f. VxWorks as source code	P.1703.56