

VME-PMC-CADDY

VME-Carrier Board for PMC Modules

VMEbus Interface

- master or slave functionality
- 4-level arbiter
- address /data up to A32/D32
- VME64-extension connector

PMC Plug-In Units

- plug-in units according to IEEE P1386/ draft 2.0 specified
- two single or one double size PMC module insertable
- VME-PCI bridge UNIVERSE CA91C142
- all PMC I/Os applied to VMEbus P2,
- option '-32P2': different P2-pinning

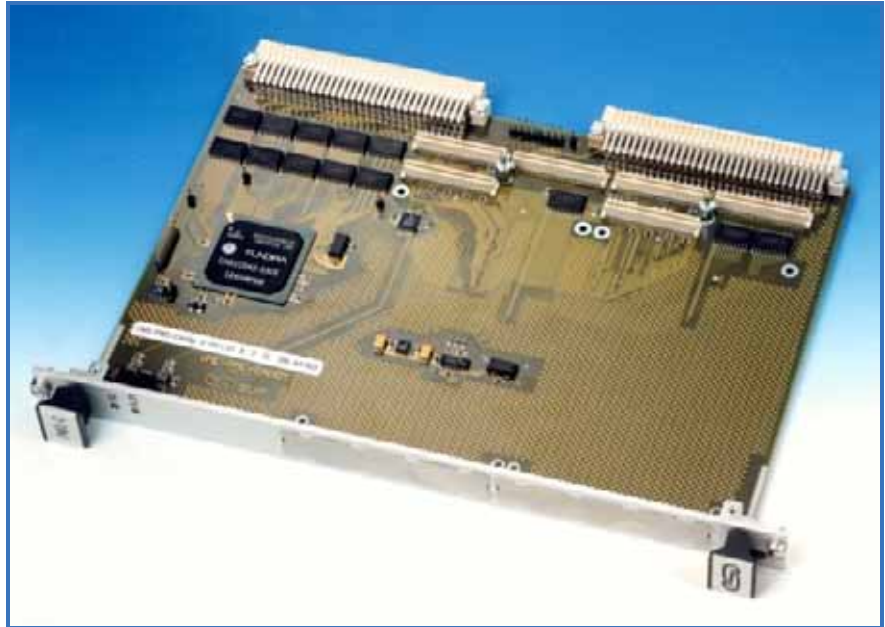

VME-PCI Link

The VMEbus unit PMC-CADDY is a VME64-base board which can carry up to two PMC modules of normal size or one module of double size.

For the VMEbus connection the VME-PCI bridge UNIVERSE CA91C142 by Tundra with an internal clock rate of 33 MHz is used.

VMEbus Interface

The CA91C142 is designed in a way that the board can either operate as slave or as master on the VMEbus. If the board operates as master, it supports a 4-level arbiter. The PMC-CADDY operates with a data width of up to 32 bits and with 32 address signals on the VMEbus. The VMEbus interrupt can be applied to any of the seven interrupt-request lines. The board is connected to the VMEbus by two 160-pin VG-connectors according to IEC603-xx on VME64 extensions.

An active VMEbus-interrupt request is shown by a red LED in the front panel and a VMEbus access onto the board is shown by a yellow LED.

PMC Plug-In Units

Both PMC plug-in units are designed according to the draft standard IEEE P1386/Draft 2.0 (except the standard I/O pin routing). It is possible therefore to insert all PMC modules which are on the market.

In addition to the connectors for the PMC-address/data and control signals, every plug-in unit of the PMC-CADDY has an I/O-connector which applies the I/O-signals of the PMC modules to VMEbus connector P2. Two different P2 pin assignments are available: In the standard configuration each P2-pin is only connected to one I/O-pin of the PMC-modules (acc. to PMC-Update of FORCE™, Table 1, Author: Wayne Fischer, Director of Strategic Programs CMC/PMC Working Groups Chair, 22.10.96).

In the option '-32P' the pin assignment is acc. to IEEE P1386/Draft 2.0, Table 6-3. This pin assignment offers the connection of the two PMC-modules via P2, because several PMC-I/O-signals are shorted at P2.

Front Panel

The front panel of the PMC-CADDY has two holes for the front panels of the PMC modules. A blank cover for free plug-in units is included in the price.

Software

Example libraries for the initialization of the board in C-Source-Code for VxWorks and OS-9 are available for a fee on a disk (MS-DOS format). Drivers for further operating systems are available on request. Please state your operating system with the version number when you order.

VME-PMC-CADDY

VME-Carrier Board for PMC Modules

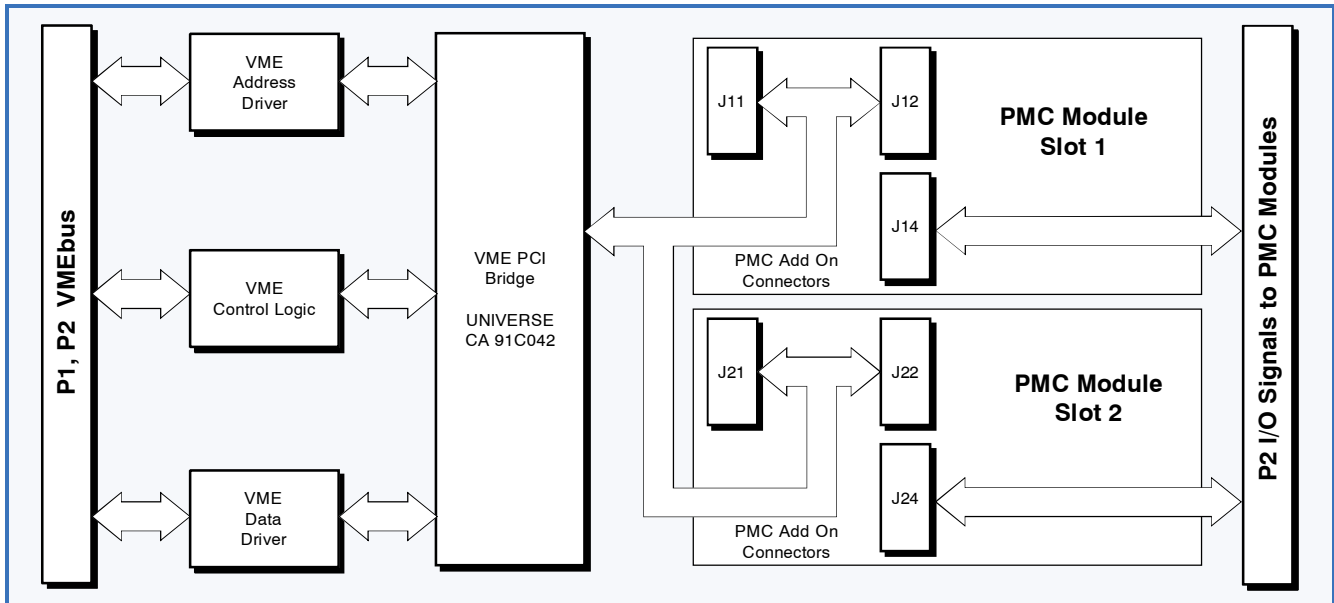

Technical Specifications:

VMEbus:	
VMEbus access:	master or slave function, A32, A24, A16; D8, D16, D32
Base address:	selectable via coding switch (no geographical addressing)
Address modifier:	standard supervisory and nonprivileged data access, extended supervisory and non-privileged data access, short supervisory and nonprivileged access
VMEbus standard:	IEEE 1014 Rev. D
VMEbus connector:	160-pole VG connector (IEC 603-xx), acc. to VME64 extension standard
LEDs:	VMEbus interrupt - red LED VMEbus access - yellow LED
PMC slots:	
Standard:	IEEE P1386 / draft 2.0
Size:	two single size or one double size module
VME PCI Bridge:	UNIVERSE CA91C142, configuration via coding switches
Voltage level:	3.3 V or 5 V (signal level)

General:		
Temperature:	0...50 °C (Order no.: V.1911.01, V.1911.11, V.1911.10)	
	-40...+75 (Order no. V.1911.02)	
Humidity:	max. 90 %, non-condensing	
Connector types:	P1, P2: VMEbus (IEC 603-xx, 160 pins) J11, J12, J21, J22: PMC address/data J14, J24: PMC I/O signals	
Board size:	160 mm x 233 mm	
VME dimensions:	6 U height, 4 HP width	
Order information:		
Designation		Order no.
VME-PMC-CADDY	VMEbus base board for two single PMC modules, P2-pin assignment acc. to PMC-Update from 22.10.96 (no interconnection between PMC-modules)	V.1911.01
VME-PMC-CADDY-T	as V.1911.01, but for extended temperature range: -40...+75 °C	V.1911.02
VME-PMC-CADDY-32P2	VMEbus base board for two single PMC modules, P2-pin assignment acc. to IEEE P1386/ Draft 2.0, Table 6-3 (interconnection between 16 pins of the PMC-modules), extended temperature range on request	V.1911.11
VME-PMC-CADDY-3.3P1	3.3V power supply directly connected to VMEbus 3.3V, not generated from 5V supply, extended temperature range on request	V.1911.10
VME-PMC-CADDY OS-9 LIB	OS-9 library (68K and Power PC systems)	V.1911.56
VME-PMC-CADDY VxWorks LIB	VxWorks library	V.1911.58
VME-PMC-CADDY-ME	English users' manual	M.1911.21